

Mosadzné koncovky Brass fittings



Funkcie

- ▶ pre rôzne aplikácie
- ▶ pre pripojenie od M5 do 2"
- ▶ poniklovaný alebo leštený povrch

- ▶ For various applications
- ▶ For connections from M5 to 2"
- ▶ With nickel-plated or polished surface

Technické údaje **Technical data**

Pracovná teplota	max. +150°C
Pracovný tlak	až 60bar
Materiály	Leštená poniklovaná mosadz (Ms58)
Závit	DIN 3852 DIN 3858
Médium	vzduch, voda, olej , para atď

Operating temperature	Max +150°C
Operating pressure	Up to 60 bar
Materials	Brass (Ms58) nickel-plated and polished
Thread	DIN 3852 DIN 3858
Medium	Air, water, oil, steam, etc.

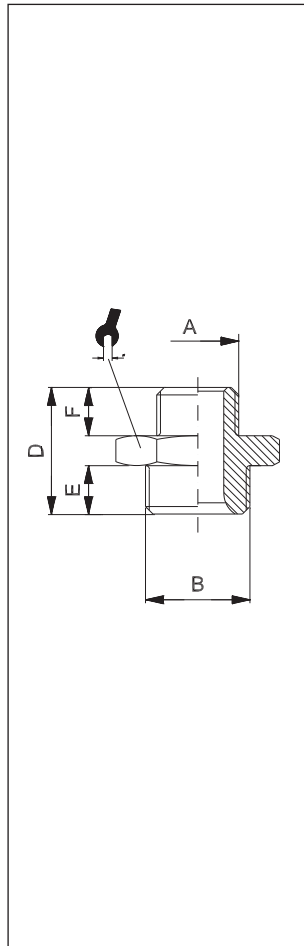

Priama spojka

Double nipple, cyl.

VT	A	B	D	E	F		
401500	M5	G ^{1/8}	17	7	5	13	100
401501	M5	M5	14	5	5	8	100
401502	G ^{1/8}	G ^{1/8}	19	7	7	14	100
401503	G ^{1/8}	G ^{1/4}	22	10	7	17	100
401505	G ^{1/4}	G ^{1/4}	25	10	10	17	100
401506	G ^{1/4}	G ^{3/8}	25	10	10	22	100
401511	G ^{1/4}	G ^{1/2}	25	9	9	22	100
401508	G ^{3/8}	G ^{3/8}	25	10	10	22	100
401509	G ^{3/8}	G ^{1/2}	28	12	10	27	100
401510	G ^{3/8}	G ^{3/4}	24	9	10	27	100
401512	G ^{1/2}	G ^{1/2}	30	12	12	27	100
401514	G ^{1/2}	G ^{3/4}	31	12	12	32	100
401515	G ^{3/4}	G ^{3/4}	31	12	12	32	100
401516	G ^{3/4}	G1	35	15	12	41	50
401518	G1	G1	38	15	15	41	25
401519	G ^{1 1/4}	G1	38	15	15	42	10
401521	G ^{1 1/4}	G ^{1 1/4}	38	16	16	42	10
401520	G ^{1 1/4}	G ^{1 1/2}	41	18	16	50	10
401522	G ^{1 1/2}	G ^{1 1/2}	45	18	18	50	10
401523	G ^{1 1/2}	G2	50	22	18	62	10
401525	G2	G2	54	22	22	64	1
401526	G2	G2 ^{1/2}	57	22	22	80	1

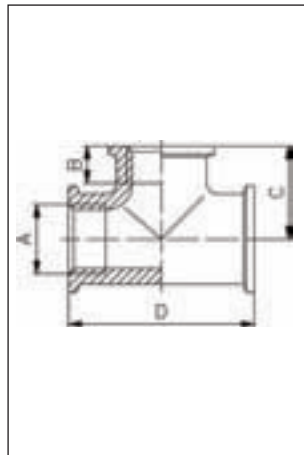

T-kus

Female T

VT	A	B	C	D	
401613	G ^{1/4}	10	16,5	35	10
401614	G ^{3/8}	11	22,5	44	10
401615	G ^{1/2}	13	25,5	51	10
401616	G ^{3/4}	15	29,5	59	10
401617	G1	16	34	75	10
401618	G ^{1 1/4}	18	44	89	10
401619	G ^{1 1/2}	18	47	92	1
401620	G2	20	51	104	1

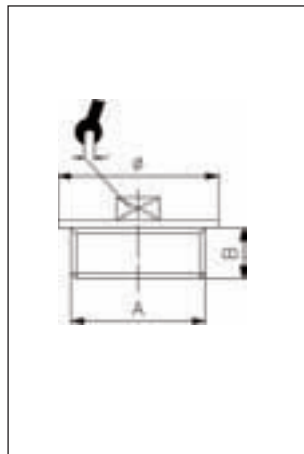

Zátka

Parallel male plug

VT	A	B	Ø		
401716	G ^{3/4}	8	34	14	10
401717	G1	9	40	17	10
401718	G ^{1 1/4}	10	52	19	10
401719	G ^{1 1/2}	10	60	22	10
401720	G2	13	73	24	10

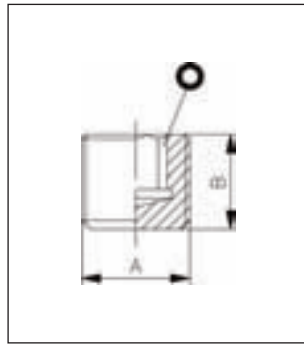

Zátka DIN 906
Male plug DIN 906

VT	A	B		
401742	R ¹ / ₈	8	5	100
401743	R ¹ / ₄	10	6	100
401744	R ³ / ₈	11	8	100
401745	R ¹ / ₂	13	10	50
401746	R ³ / ₄	17	12	25

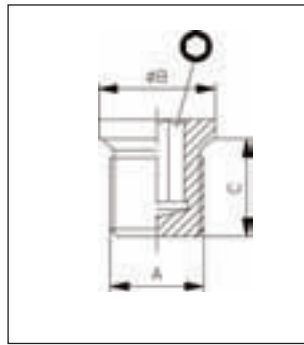

Zátka DIN 908
Parallel male plug

VT	A	ØB	C		
401752	G ¹ / ₈	14	8	5	100
401753	G ¹ / ₄	18	12	6	100
401754	G ³ / ₈	22	12	8	100
401755	G ¹ / ₂	26	14	10	50
401756	G ³ / ₄	32	16	12	50

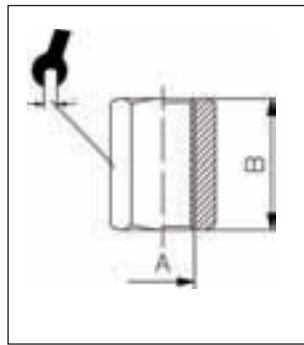

Spojka Mufka
Sleeve

VT	A	B		
401801	M5	10	8	100
401802	G ¹ / ₈	15	13	100
401803	G ¹ / ₄	22	17	100
401804	G ³ / ₈	22	22	100
401805	G ¹ / ₂	26	27	50
401806	G ³ / ₄	34	32	25
401807	G1	38	41	10

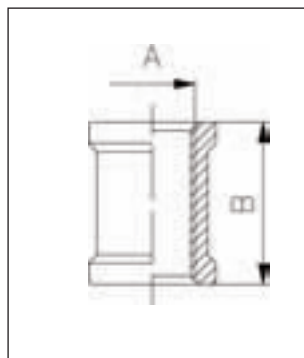

Spojka Mufka
Sleeve

VT	A	B	
401815	G ¹ / ₂	30	10
401816	G ³ / ₄	30	10
401817	G1	32	10
401818	G1 ¹ / ₄	38	10
401819	G1 ¹ / ₂	40	10
401820	G2	43	10
401821	G2 ¹ / ₂	55	1
401822	G3	65	1

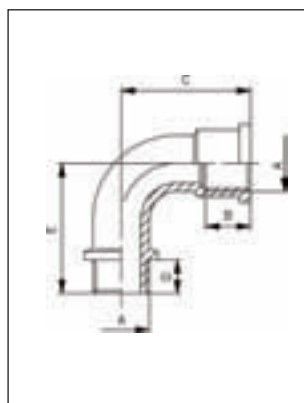

L-kus
Male - female elbow

VT	A	B	C	D	E	
401643	G ¹ / ₄	10	25	8	26	10
401644	G ³ / ₈	12	28	9	31	10
401645	G ¹ / ₂	11	31	10	35	10
401646	G ³ / ₄	15	38	12	42	10
401647	G1	17	46	14	46	10
401648	G1 ¹ / ₄	16	54	17	55	10
401649	G1 ¹ / ₂	21	60	20	65	1
401650	G2	23	76	22	71	1

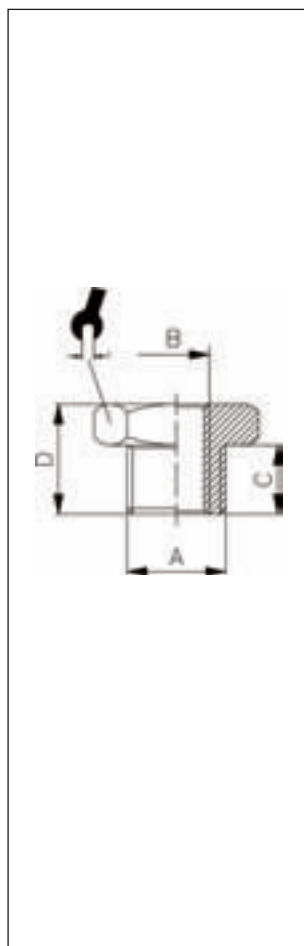

Redukcia

Reducer

VT	A	B	C	D		
401301	G ¹ / ₈	M5	7	11	13	100
401302	G ¹ / ₄	G ¹ / ₈	9	13	17	100
401303	G ³ / ₈	G ¹ / ₄	10	15	19	100
401304	G ³ / ₈	G ¹ / ₈	9	14	19	100
401306	G ¹ / ₂	G ¹ / ₄	10	15,5	24	50
401307	G ¹ / ₂	G ¹ / ₈	10	15,5	24	50
401308	G ¹ / ₂	G ³ / ₈	10	15,5	24	50
401309	G ³ / ₄	G ¹ / ₂	12	19	32	50
401310	G ³ / ₄	G ³ / ₈	12	19	32	50
401311	G ³ / ₄	G ¹ / ₄	12	19	32	50
401312	G1	G ³ / ₄	15	23	41	25
401313	G1	G ¹ / ₂	15	23	41	25
401314	G1	G ³ / ₈	15	23	41	25
401315	G ¹ / ₄	G1	15	22	42	10
401316	G ¹ / ₄	G ³ / ₄	15,5	22	42	10
401317	G ¹ / ₄	G ¹ / ₂	15,5	22	42	10
401318	G ¹ / ₂	G ¹ / ₄	15	23	50	10
401319	G ¹ / ₂	G1	17	25	50	10
401320	G ¹ / ₂	G ³ / ₄	15,5	22	50	10
401321	G2	G ¹ / ₂	18	26,5	60	10
401322	G2	G ¹ / ₄	15	24,5	60	10
401323	G2	G1	18	26	60	10
401324	G ² / ₁	G2	22	30	78	1

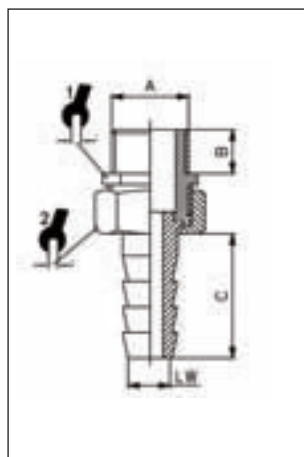

Priama spojka

Parallel straight adaptor, full brass

VT	A	LW	B	C			
401401	G ³ / ₈	10	9	22	22	27	100
401402	G ¹ / ₂	13	10	23	27	34	100
401403	G ³ / ₄	19	10	24	34	42	100
401404	G1	25	15	32	42	50	100
401405	G ¹ / ₄	32	16	38	50	55	100
401406	G ¹ / ₂	38	18	47	55	58	50
401407	G2	50	22	56	70	77	50

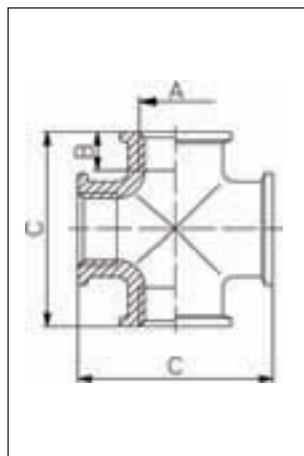

Križ

Female cross

VT	A	B	C	
401604	G ³ / ₈	12,0	43	25
401605	G ¹ / ₂	16,5	49	25
401606	G ³ / ₄	15,7	62	10
401607	G1	20,5	80	10

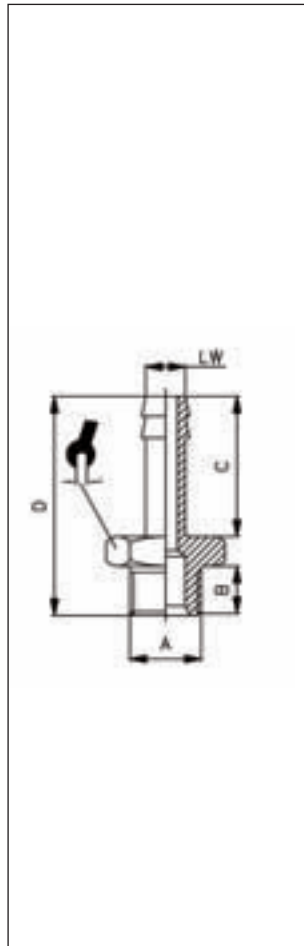

Hadicový nátrubok s vonkajším závitom 1/3

Hose connector 1/3

VT	LW	A	B	C	D		
401002	3	M5	4,5	9	16	8	100
401012	6	G ¹ / ₄	9	22	36	17	100
401014	9	G ¹ / ₄	9	22	36	17	100
401015	10	G ¹ / ₄	8,5	22	36	17	100
401017	13	G ¹ / ₄	9	25	40	17	100
401022	6	G ³ / ₈	9	18	36	19	100
401024	9	G ³ / ₈	9	22	36	19	100
401027	13	G ³ / ₈	10	34	48	19	100
401032	6	G ¹ / ₂	10	26	41	24	100
401034	9	G ¹ / ₂	10	26	41	24	100
401037	13	G ¹ / ₂	10	35	50	24	100
401039	19	G ¹ / ₂	11	30	47	24	25
401043	13	G ³ / ₄	12	25	44	30	25
401045	19	G ³ / ₄	13	30	49	32	25
401048	25	G ³ / ₄	10	35	51	32	25
401053	25	G1	13	35	56	37	25
401056	32	G1	10,5	38,5	55	38	10
401063	32	G ¹ / ₄	12	39	58	50	10
401066	38	G ¹ / ₂	14	47	68	55	10
401073	50	G2	19	54	80	70	10

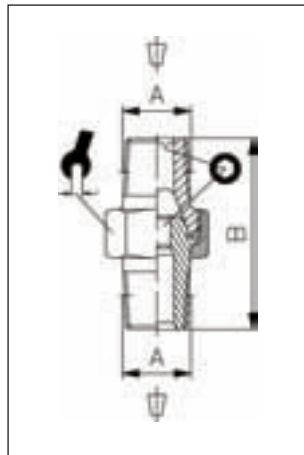

Spojka s vnútorným šesťhranom

Double nipple con. detachable

VT	A	B	Ø			
306002	R ¹ / ₈	27	5,3	15	5	25
306004	R ¹ / ₄	34	6,3	19	6	25
306006	R ³ / ₈	36	8,5	22	8	10
306008	R ¹ / ₂	40	13	27	12	10
306010	R ³ / ₄	52	15	36	14	10
306012	R1	65	20	46	19	5
306014	R ¹ / ₈ -R ¹ / ₄	30	5,3	15	5	5
306015	R ¹ / ₄ -R ³ / ₈	35	6,3	19	6	5

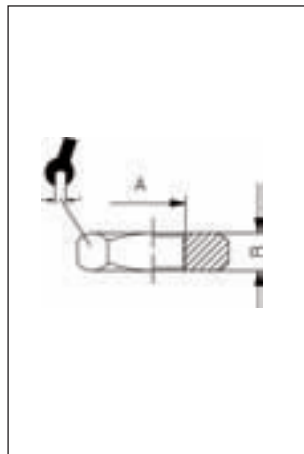
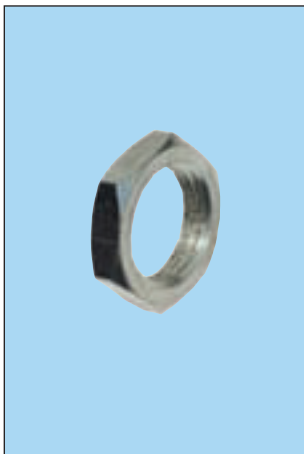

Matica

Nut

VT	A	B		
401362	G ¹ / ₈	4,5	14	100
401363	G ¹ / ₄	5	17	100
401364	G ³ / ₈	4,5	22	100
401365	G ¹ / ₂	5	27	50
401366	G ³ / ₄	5	32	50
401367	G1	8	41	10
401368	G ¹ / ₄	6	50	10
401369	G ¹ / ₂	7	56	10
401370	G2	8	68	10

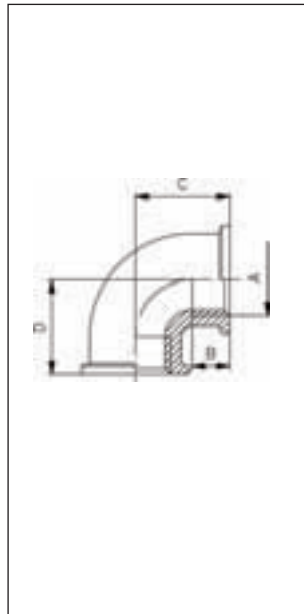

Koleno 90°

Elbow 90°

VT	A	B	C	D	■
401633	G ¹ / ₄	8	15	15	10
401634	G ³ / ₈	12	20	20	10
401635	G ¹ / ₂	13	24	24	10
401636	G ³ / ₄	15	30	30	10
401637	G1	18	33	33	10
401638	G1 ¹ / ₄	18	47	47	10
401639	G1 ¹ / ₂	19	52	52	1
401640	G2	22,5	60	60	1

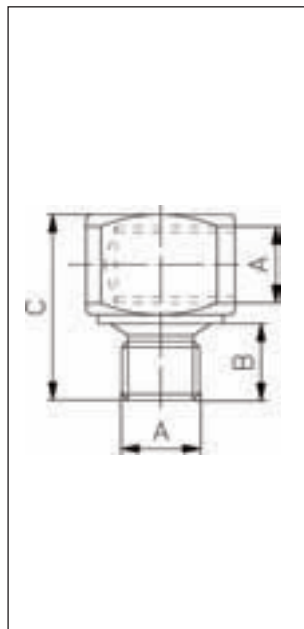

Prietokové oko 90°

Blockshaped elbow 90°

VT	A	B	C	■
401901	M5	5	13	10
401902	G ¹ / ₈	6,5	16,5	10
401903	G ¹ / ₄	8	20	10

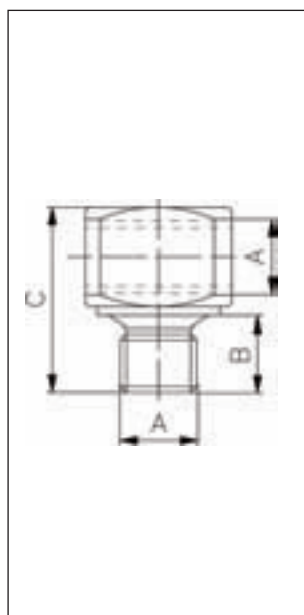

Prietokové oko

Blockshaped T - F.F.M.

VT	A	B	C	■
401922	G ¹ / ₈	6,5	16,5	100
401923	G ¹ / ₄	8	20	100